

# ELIMINATOR<sup>®</sup>

**NEXGEN's Perforator for Plastic Bottles & Aluminum Cans**

## General Specifications

- Performance . . . . . Process HDPE, PET, UBC and Aluminum Cans; Full or Empty, With or Without Lids
- Models . . . . . 36", 48" and 60" wide (feed opening)
- Motor . . . . . Dual shaft mounted gear motors; 3 and 5 HP combinations (depending on application)
- Perforator Blades . . . . . 2 interlocking sets of 1/4" thick hi-alloy quenched and tempered A-514 steel blades. 14" diameter infeed and 12" diameter out-feed
- In-feed Shaft . . . . . 30-60 RPM
- Out-feed Shaft . . . . . 38-75 RPM  
*RPM's depend on application and may vary*
- Bearings . . . . . Corrosion resistant Browning Bev Gold bearings; 2 7/16" dia. pillowblock with extended grease tubes for easy maintenance
- Blade Drive Shafts . . . . . 2 1/2" square
- Stand & Hopper . . . . . Designed to customer's application
- Unit Weight . . . . . Approximate weights (including stand and in-feed hopper):  
36" wide unit: 2,900 lbs.  
48" wide unit: 3,400 lbs.  
60" wide unit: 4,000 lbs.
- Through-put Volumes . . . . . 0.75 (36" wide unit), 1.0 (48" wide unit), and 1.25 (60" wide unit) cubic yards per minute (Volume will depend on material, feed rate and horsepower)
- Other Features . . . . . Hinged and removable covers for easy shaft removal and maintenance; UL Listed enclosure to house (2) VFD motor starters, start/stop switch and PLC to control in-feed conveyor and discharge conveyor for automatic operation; self-cleaning sequence for jams; stainless steel floor and fasteners

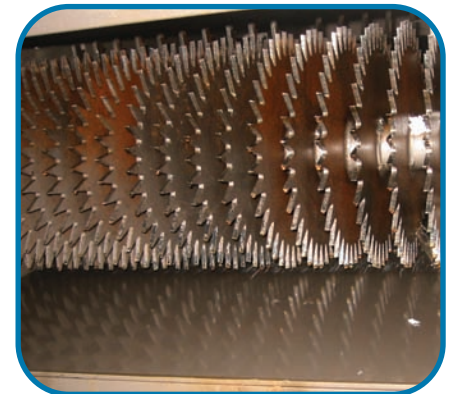

# ELIMINATOR<sup>®</sup> Perforator Dimensions:

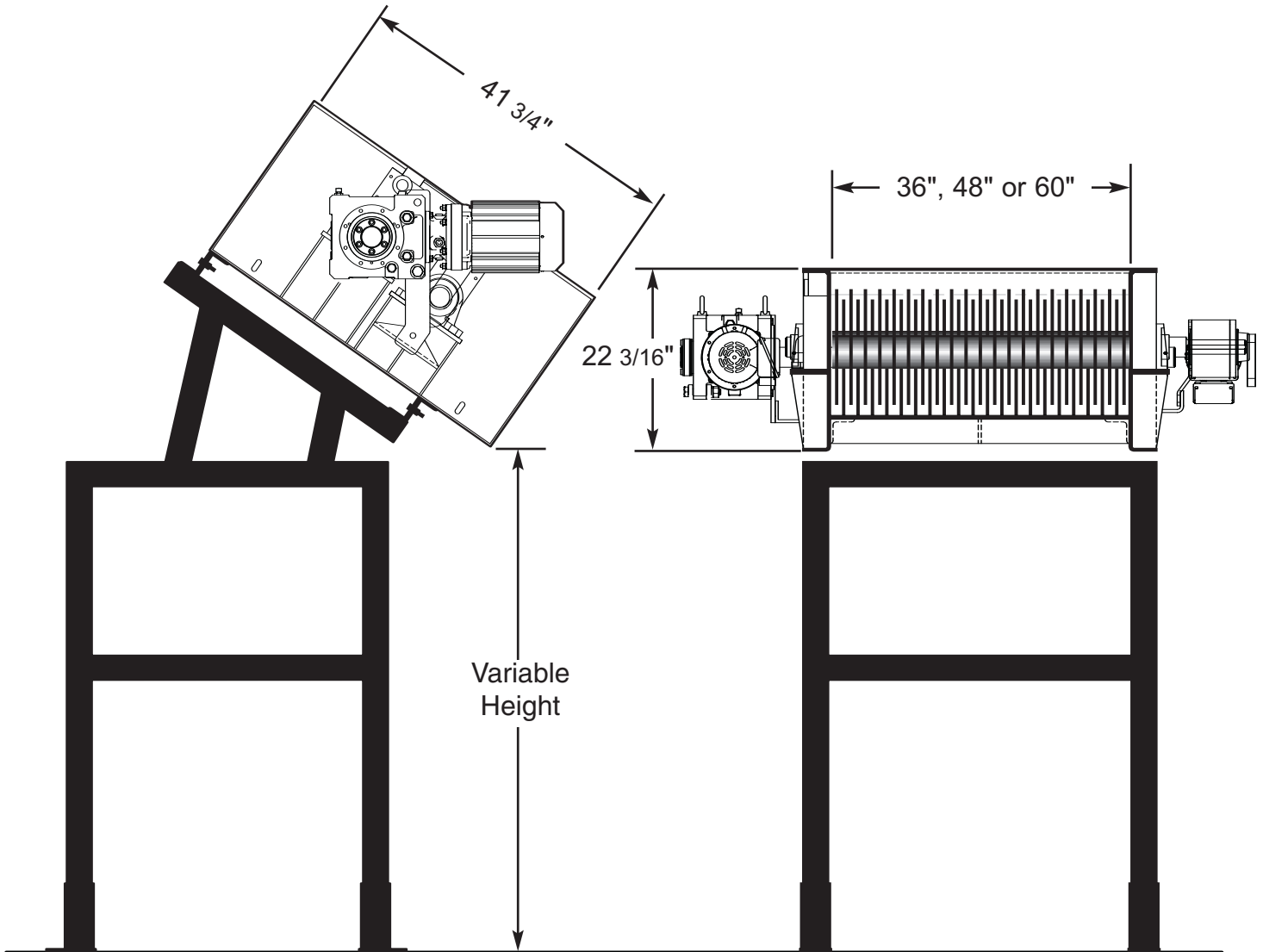

**SIDE VIEW**

**DRAWING  
NOT TO  
SCALE**

**FRONT VIEW**



**MARATHON EQUIPMENT COMPANY**

P.O. Box 1798 • Vernon, AL 35592-1798 USA • (205) 695-9105 fax (205) 695-7250 **1-800-633-8974**  
 130 Hwy. 339 • Yerington, NV 89447 USA • (775) 463-4030 fax (775) 463-4531 **1-800-624-5724**  
 1102 Industrial Park Rd. • Clearfield, PA 16830 USA • (814) 765-0200 fax (814) 765-2072 **1-800-922-7062**  
 1102 Hwy 96 W • Fayette, AL 35555 USA • (205) 932-2282 fax (205) 904-8392

Pictures in this literature are illustrative only. Specifications are subject to change without notice in order to accommodate improvements to the equipment. Certified in compliance with ANSI and OSHA standards. Products must be used with safe practice and in accordance with regulations and standards.

